

YONG YUAN VALVE

FLANGED CHECK VALVE

YFKB CLASS 300LB SERIES

Standard Features

- WCB Cast Body and AISI 1025 Adapter
- Integral or replaceable seat available
- Valves Designed to API 6D ASME B16.34 standard
- Valves Flanges ASME B16.5 standard
- 316SS disc standard
- Bolted bonnet with tap is standard
- NACE MR0175
- 6 in sserted pin spring type

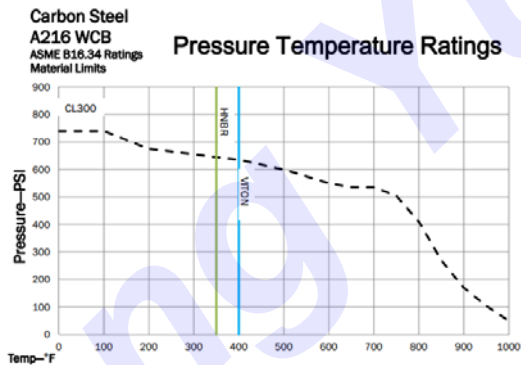
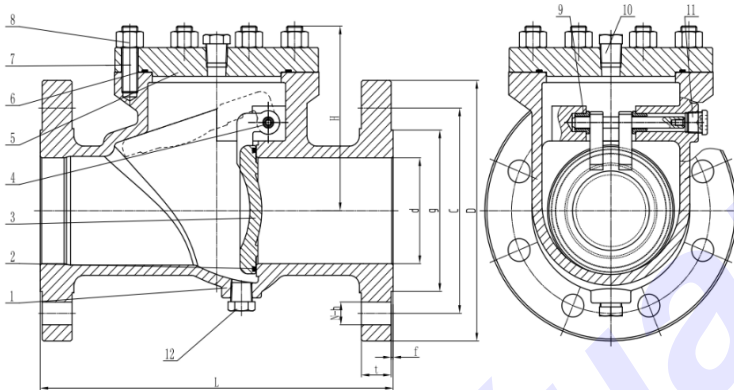

Parts & Materials

NO.	Description	Material
1	Body	ASTM A216 WCB
2	Seat	HNBR-90
3	Disc	ASTM A351 CF8M
4	Valve disc shaft	ASTM A479 SS316
5	Bonnet	ASTM A105
6	Bonnet Seal	SS316+graphite
7	Stud	ASTM A193 B7M
8	Nut	ASTM A194 2HM
9	Bushing	ASTM A479 SS316
10	Bonnet screw	ASTM A105
11	plug	ASTM A105
12	Drain screw	ASTM A105

SPECIFICATIONS

NOMINAL PRESSURE	740Psi	5.1 Mpa
SHELL STRENGTH (WATER)	1125 Psi	7.8 Mpa
SEALING TEST (WATER)	815 Psi	5.8 Mpa
AIR SEAT PING (AIR)	80.8 Psi	0.55 Mpa

Dimensions(in)

NPS	L	D	C	g	d	N	h	t	f	H	Weight (lbs)
2"	10.50	6.50	5.00	3.63	1.94	8	0.75	0.82	0.06	5.29	38.80
3"	12.50	8.25	6.62	5.00	2.94	8	0.88	1.06	0.06	6.26	66.45
4"	14.00	10.00	7.88	6.18	3.94	8	0.88	1.19	0.06	7.09	102.65
6"	17.50	12.50	10.62	8.50	5.94	12	0.88	1.38	0.06	8.19	178.35
8"	21.00	15.00	13.00	10.62	7.94	12	1.00	1.56	0.06	10.43	357.81
10"	24.50	17.50	15.25	12.75	9.94	16	1.13	1.81	0.06	12.13	535.17
12"	28.00	20.50	17.75	15.00	11.94	16	1.25	1.94	0.06	14.57	826.85

TEL:0086-579-8715288
E-mail:cnyvc@cnyvc.com

0086-579-8725688
yu@cnyvc.com

FAX:0086-579-87151442
HTTP:www.oil-fieldvalve.com